

i
information
bulletin

B-doubles & Higher Mass Limits Trucks

May 2004



Introduction

This information bulletin summarises the conditions for operating B-doubles and Higher Mass Limits vehicles in Victoria.

High productivity vehicles, such as B-doubles and vehicles at Higher Mass Limits, are important to the efficiency of the freight task in Victoria. The larger capacity of these vehicles also reduces the number of vehicles required to transport a given amount of freight.

The extent of the potential benefit of these vehicles is related to the degree of access to the Victorian road network. Access in Victoria is allowed where these vehicles can operate safely with other traffic and where the road infrastructure (road pavements and bridges) is suitable.

Implementation of Higher Mass Limits

Victoria implemented the Higher Mass Limits on 1 July 1999. At the time of publication of this bulletin approximately 99% of the main road network has been approved for use by B-doubles and Higher Mass Limits vehicles.

Operating Requirements

The operating requirements for B-doubles and Higher Mass Limits trucks are contained in this information bulletin. It also lists the prohibited bridges and provides maps of approved main roads. Main roads include freeways, highways and arterial roads.

Full details of the operating requirements are contained in the Road Safety (Vehicles) Regulations 1999 (RSVR) and in associated Victoria Government Gazette Notices.

The notices serve as a general permit for B-doubles and vehicles operating at Higher Mass Limits in Victoria, irrespective of the State or Territory of registration.

Documentation

You must carry in the driving compartment of your vehicle, one or more of the following documents authorising travel on the road you are using:

- 1) This information bulletin;
- 2) The VicRoads publication, *Local Roads Approved for B-doubles and Higher Mass Limits Trucks*, See page 10;
- 3) A permit issued by VicRoads; and
- 4) For vehicles permitted to exceed 4.3 metres in height, a copy of the current edition of the VicRoads information bulletin, *Height Clearance on Roads*.

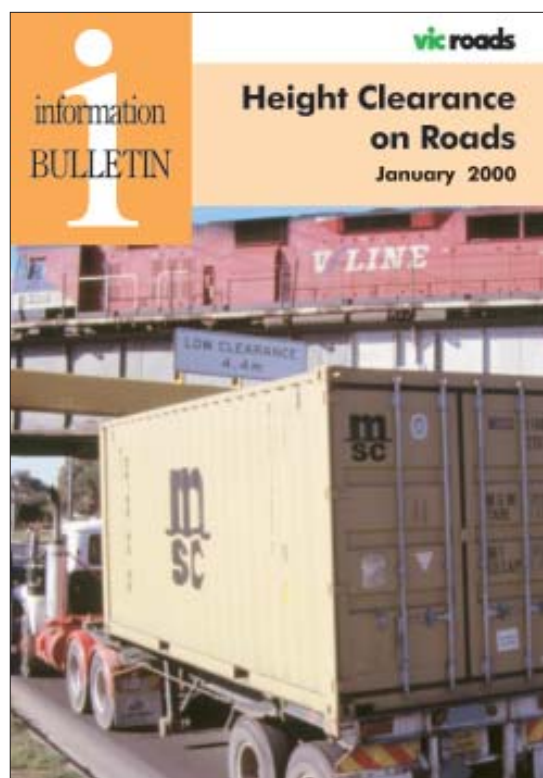

The applicable documents must be produced if requested by a VicRoads Officer or a Police Officer.

Using this Bulletin

Before operating any B-double or Higher Mass Limits vehicle in Victoria you need to:

- 1. Check the mass and the routes that apply to the truck you are driving:**



Page 4 - 5

- 2. Check which roads you are permitted to use:**

- a) Interstate routes in Victoria**



Page 19

- b) Main roads* in rural Victoria**



Pages 20 - 25

- c) Main roads* in Melbourne**



Pages 26 - 31

- d) Roads in rural cities and towns**



Pages 32 - 39

- e) Local roads**



Page 10

- 3. Check for any bridges you cannot cross:**

- a) B-doubles (except mini B-doubles up to 50.0 tonnes) must not cross the bridges listed in Table 4:**



Pages 13 - 14

- b) B-doubles or semi-trailers, with tri-axles at Higher Mass Limits, must not cross the bridges listed in Table 5:**



Page 15

* Main roads include freeways, highways, arterial roads and main roads.

General Mass Limits Vehicles







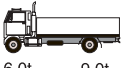
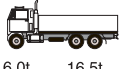

Access to the Victorian road network depends upon the vehicle type and mass limits. Table 1A shows typical vehicle types eligible to operate in Victoria at general mass limits.

For each vehicle type the approved routes are colour coded and displayed in the following maps. Vehicles (shown in the unshaded area on the table below) can travel on all roads in Victoria.

The vehicles in the shaded area may only travel on approved roads and are not permitted to travel over some bridges. These bridges are listed in Table 4 and are shown on the maps by the symbol: 

If your particular vehicle is not shown in Table 1A, contact VicRoads for further advice.

Table 1A

General Mass Limits							
Vehicle Type	General Mass Limits (tonnes)	Green Roads	Orange Roads	Red Roads	Blue Bridges	Red Bridges	Local Roads
 6.0t 9.0t	15.0	Yes	Yes	Yes	Yes	Yes	Yes *
 6.0t 16.5t	22.5	Yes	Yes	Yes	Yes	Yes	Yes *
 6.0t 9.0t 16.5t	31.5	Yes	Yes	Yes	Yes	Yes	Yes *
 6.0t 16.5t 16.5t	39.0	Yes	Yes	Yes	Yes	Yes	Yes *
 6.0t 16.5t 20.0t	42.5	Yes	Yes	Yes	Yes	Yes	Yes *
 6.0t 16.5t 16.5t 16.5t 19m long B-double <i>See page 8 for details</i>	50.0	Yes	Yes	Yes	Yes	Yes	Yes *
 6.0t 16.5t 16.5t 16.5t 19m long B-double	55.5	Yes	No	Yes	No	Yes	By permit **
 6.0t 16.5t 16.5t 16.5t 25m long B-double	55.5	Yes	No	Yes	No	Yes	By permit **
 6.0t 16.5t 16.5t 20.0t	59.0	Yes	No	Yes	No	Yes	By permit **
 6.0t 16.5t 20.0t 20.0t	62.5	Yes	No	Yes	No	Yes	By permit **

Note: * Travel on all local roads is approved, provided there is not a 'no truck' sign or a sign displaying a load limit that is less than the mass of your vehicle and load.



** Travel on local roads is by either of two permits:

- 1) A general permit (Victoria Government Gazette Notice). Check the VicRoads publication: *Local Roads Approved for B-doubles and Higher Mass Limits Trucks*; or
- 2) A VicRoads permit for specific local roads - seek written Council approval before you apply for a permit from VicRoads.

Higher Mass Limits Vehicles







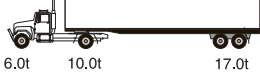
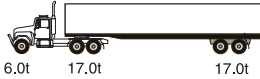
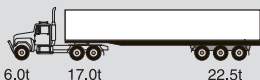



Table 1B shows typical vehicle types eligible to operate in Victoria at Higher Mass Limits.

For each vehicle type the approved routes are colour coded and displayed in the following maps. Vehicles (shown in the unshaded area on the table below) can travel on all roads in Victoria.

The vehicles in the shaded area may only travel on approved roads and are not permitted to travel over some bridges. These bridges are listed in Tables 4 and 5 and are shown on the maps by the symbols.  

If your particular vehicle is not shown in Table 1B, contact VicRoads for further advice.

Table 1B

Higher Mass Limits							
Vehicle Type	Higher Mass Limits (tonnes)	Green Roads 	Orange Roads 	Red Roads 	Blue Bridges 	Red Bridges 	Local Roads
 6.0t 10.0t	16.0	Yes	Yes	Yes	Yes	Yes	Yes *
 6.0t 17.0t	23.0	Yes	Yes	Yes	Yes	Yes	Yes *
 6.0t 10.0t 17.0t	33.0	Yes	Yes	Yes	Yes	Yes	Yes *
 6.0t 17.0t 17.0t	40.0	Yes	Yes	Yes	Yes	Yes	Yes *
 6.0t 17.0t 22.5t	45.5	Yes	Yes	No	No	No	By permit **
 6.0t 17.0t 17.0t 17.0t 19m long B-double	57.0	Yes	No	Yes	No	No	By permit **
 6.0t 17.0t 17.0t 17.0t 25m long B-double	57.0	Yes	No	Yes	No	No	By permit **
 6.0t 17.0t 17.0t 22.5t	62.5	Yes	No	No	No	No	By permit **
 6.0t 17.0t 22.5t 22.5t	68.0	Yes	No	No	No	No	By permit **

Note: * Travel on all local roads is approved, provided there is not a 'no truck' sign or a sign displaying a load limit that is less than the mass of your vehicle and load.

** Travel on local roads is by either of two permits:

- 1) A general permit (Victoria Government Gazette Notice). Check the VicRoads publication: *Local Roads Approved for B-doubles and Higher Mass Limits Trucks*; or
- 2) A VicRoads permit for specific local roads - seek written Council approval before you apply for a permit from VicRoads.

Axle Mass Limits

Axle mass limits are shown in Table 2 below.

Table 2 – Axle Mass

Type of Axle	Non-Road Friendly Suspension	Road Friendly Suspension
Steer Axle	6.0 tonnes	6.0 tonnes
Single Axle	9.0 tonnes	10.0 tonnes
Tandem axle group	16.5 tonnes	17.0 tonnes
Tri-axle group	20.0 tonnes	22.5 tonnes

Note:

To be eligible for Higher Mass Limits all axles, other than steer axles, must have 4 tyres each. The only exception is tandem axle groups with 6 tyres, which are eligible for an increase from 13.0 tonnes to 14.0 tonnes.

Gross Mass

The gross mass of a vehicle is the lesser of:

- 1) The mass limit in Table 1A or 1B;
- 2) The sum of its axle masses in Table 2;
- 3) The mass limits according to its axle group spacing, page 7;
- 4) The motor vehicle’s GVM;
- 5) The prime mover’s GCM and the trailer’s GTM.

Road Friendly Suspension

Higher Mass Limits only apply to vehicles fitted with road friendly suspensions. These include some air and steel suspension types.

Road friendly suspension systems reduce the impact of laden axles on road pavements and most bridge structures. They do this by ensuring that the load is more evenly distributed on the wheels and by reducing the dynamic impact of the axles.

(Courtesy of Holland Hitch)



An example of a road friendly suspension

For a suspension system to be considered as road friendly, and therefore eligible for Higher Mass Limits, it must:

- 1) have been certified as road friendly by the Commonwealth Department of Transport & Regional Services,
- OR
- 2) be an air bag suspension system that was fitted to a vehicle before 1 January 2000.

The list of certified road friendly suspensions is available on the Commonwealth Department of Transport & Regional Services website at:

www.dotrs.gov.au/transreg/str_certroad_friendly.htm

Mixed Suspensions on a Combination

Vehicles do not require road friendly suspension on all axle groups to obtain an increase in mass. However, the increase in mass is limited to those axles with road friendly suspensions.

Mass Management Accreditation

In addition to having road friendly suspensions, operators who intend to operate a tri-axle group at Higher Mass Limits, must be accredited to the Mass Management Module of the National Heavy Vehicle Accreditation Scheme, or other VicRoads approved mass management schemes.

The mass management module requires operators to have an approved auditable system that ensures legal loading 100% of the time.

For further details on the scheme, please refer to VicRoads' Information Bulletin, *Mass Management Accreditation Guide, April 2000*.

Axle Group Spacings

The spacings between axle groups are controlled to minimize the impact of trucks on bridges.

The distance between axle groups determines the allowable mass over those axle groups. See Figure 1 for an example.

Minimum axle spacings for trucks, semi-trailers and B-doubles are set out in Table 6, on page 16.

As an example, Figure 1 shows the minimum spacings to operate at the maximum mass for a Tri-Tri B-double. If any of the axle spacings are less than shown, use Table 6 to determine the reduced allowable mass according to the axle spacing.

In this example, an overall axle spacing of 21.0 metres is required to achieve 62.5 tonnes. If this distance is less, eg 20.5 metres, Table 6 shows a maximum gross weight of 60.0 tonnes. This test applies to all other spacings between groups in the combination.

Vehicles with road friendly suspensions operating at the Higher Mass Limits have the same axle spacing requirements and limitations as vehicles operating at the general mass limits, as set out in Table 6. In addition to the mass limits in Table 6, vehicles with road friendly suspensions are entitled to the following increases:

- 1) 1.0 tonne for each single axle with 4 tyres or a tandem axle group with 6 tyres;
- 2) 0.5 tonne for each tandem axle group with 8 tyres;
- 3) 2.5 tonnes for each tri-axle group with 12 tyres.

Figure 1 – Axle spacing requirements for Tri-Tri B-doubles.

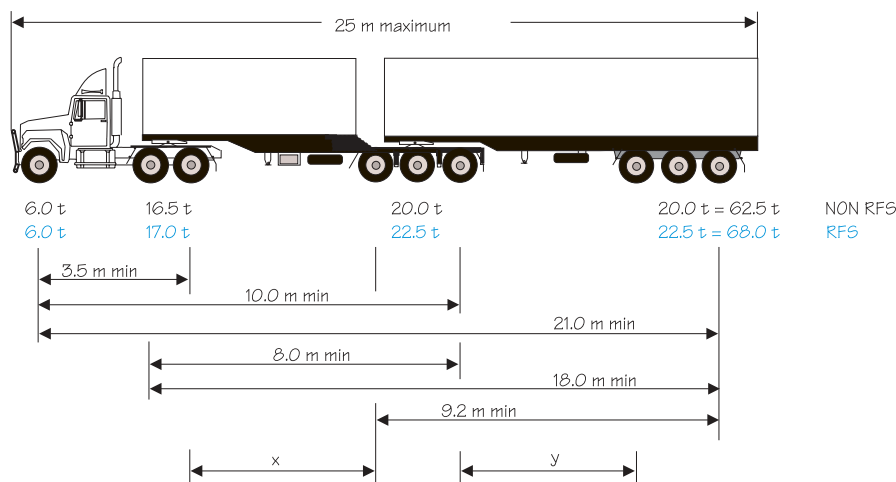

In addition, Tri-Tri B-doubles must comply with the “balanced clear space rule” under which Y must not lie outside the range X - 1.0 and X + 1.3.

Note: RFS = Road Friendly Suspension.

Mini B-doubles

Mini B-doubles, up to 19.0 metres in length, have the following mass and access requirements:

- 1) 50.0 tonnes gross mass, with any suspension types, have general access provided the axle group spacings comply with Table 7 on page 17.
- 2) 55.5 tonnes gross mass, with any suspension types, can use approved B-double routes only, provided the axle group spacings comply with Table 6 on page 16.
- 3) 57.0 tonnes gross mass, with road friendly suspension, can use approved B-double routes only, provided the axle group spacings comply with Table 6 on page 16.

Examples of the minimum axle spacings for 7 axle Mini B-doubles are shown in Figure 2.

Figure 2 – Axle spacing requirements for Mini B-doubles.

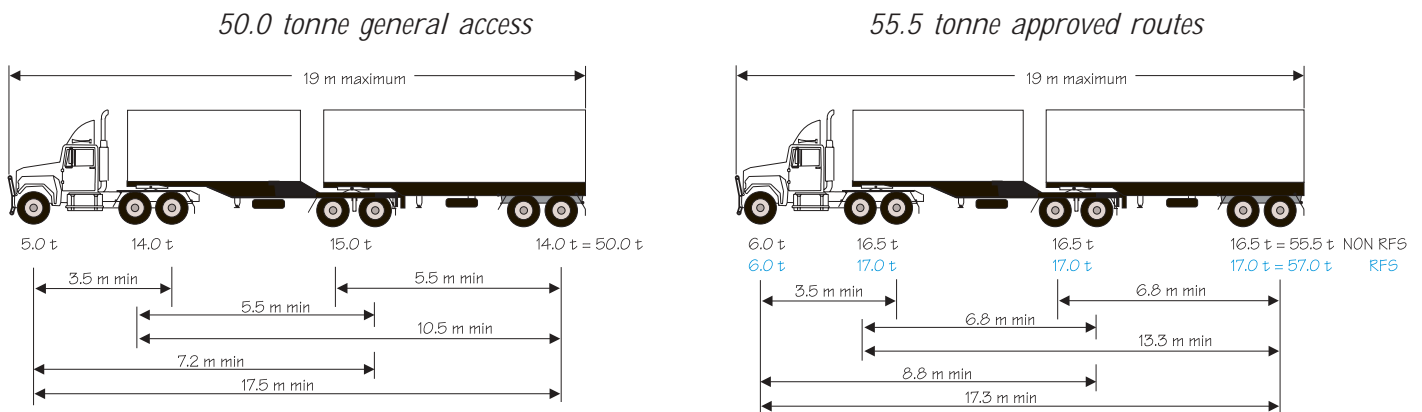

Construction Standards for Vehicles

Vehicles must be constructed to the specifications in the Australian Design Rules and the Victorian Road Safety (Vehicles) Regulations 1999. For B-doubles this includes:

- 1) Spray suppression mudguards on all axles;
- 2) Anti-lock brakes on prime movers:
 - a) built after 1989; or
 - b) first used in a B-double after 1993; or
 - c) used in a B-double that includes a road tank vehicle carrying dangerous goods;
- 3) Anti-lock brakes must be fitted to both semi-trailers, regardless of when they were built, if one (or both) of the semi-trailers is a road tank vehicle carrying dangerous goods;
- 4) Specific B-double braking standards;
- 5) Specific B-double coupling standards; and
- 6) A LONG VEHICLE sign at the rear if the vehicle exceeds 22 metres in length.



Mini B-doubles are more manoeuvrable than conventional semi-trailers

Note: The sixth edition of the Australian Code for the transport of Dangerous Goods by road and rail, defines a road tank vehicle as "A road vehicle of which a tank forms part or to which a tank is attached".

Dimension Limits

The maximum dimensions for vehicles are specified in the Victorian Road Safety (Vehicles) Regulations 1999. These include:

- 1) Length
 - a) Rigid truck 12.5 metres
 - b) Semi-trailer combination 19.0 metres
 - c) B-double 25.0 metres;
- 2) Width 2.5 metres;
- 3) Height 4.3 metres, except for the following articulated vehicles which may operate up to 4.6 metres:
 - a) Car carriers carrying substantially complete vehicles, including caravans or trailers;
 - b) Vehicles carrying livestock;
 - c) Tri-axle semi-trailers carrying hay at 42.5 tonnes and B-doubles carrying hay at 62.5 tonnes; and
 - d) Vans carrying cubic freight, provided the vehicle's stability is maintained by:
 - i) Each semi-trailer having at least 50% of its deck length no more than 1.2 metres above the ground;
 - ii) Each semi-trailer having air suspension; and
 - iii) The gross mass of the vehicle is at least 10% less than the general mass limits. ie. 10% less than 42.5 tonnes for 6 axle semi-trailers and 10% less than 62.5 tonnes for 9 axle B-doubles.

Routes

General Access

The following common vehicle types, which are illustrated in the unshaded areas in Tables 1A and 1B on pages 4 and 5, have general access in Victoria:

- 1) Rigid trucks at general and Higher Mass Limits;
- 2) Prime mover/semi-trailer combinations at general mass limits and Higher Mass Limits, provided any triaxle group does not exceed 20.0 tonnes;
- 3) Mini B-doubles up to 50.0 tonnes.

Restricted Access

The following vehicles, which are illustrated in the shaded areas in Tables 1A and 1B on pages 4 and 5, have restricted access to the road network:

- 1) Prime mover and semi-trailer combination with a tri-axle group at Higher Mass Limits. eg 6-axle combination at 45.5 tonnes;
- 2) Mini B-doubles exceeding 50.0 tonnes;
- 3) B-doubles at general mass limits eg 9-axle B-doubles at 62.5 tonnes;
- 4) B-doubles at Higher Mass Limits eg 9-axle B-doubles at 68.0 tonnes;

These restricted access vehicles must only travel on approved routes as indicated in Tables 1A and 1B and shown on the maps in this bulletin;

In addition:

- a) B-doubles at general mass limits must not cross the bridges listed in Table 4 on pages 13 and 14; and
- b) B-doubles operating at Higher Mass Limits and semi-trailers with a tri-axle at the Higher Mass Limits must not cross the bridges listed in Tables 4 and 5 on pages 13 - 15.

Local Roads

General access vehicles can travel on all roads in Victoria including local roads, except where specifically prohibited.

Restricted access vehicles can travel on most main roads, and local roads where:

- 1) The local road is listed in the VicRoads publication - *Local Roads Approved for B-doubles and Higher Mass Limits Trucks - May 2004*.

(Copies of this publication can be obtained by contacting VicRoads or by viewing the VicRoads' website).

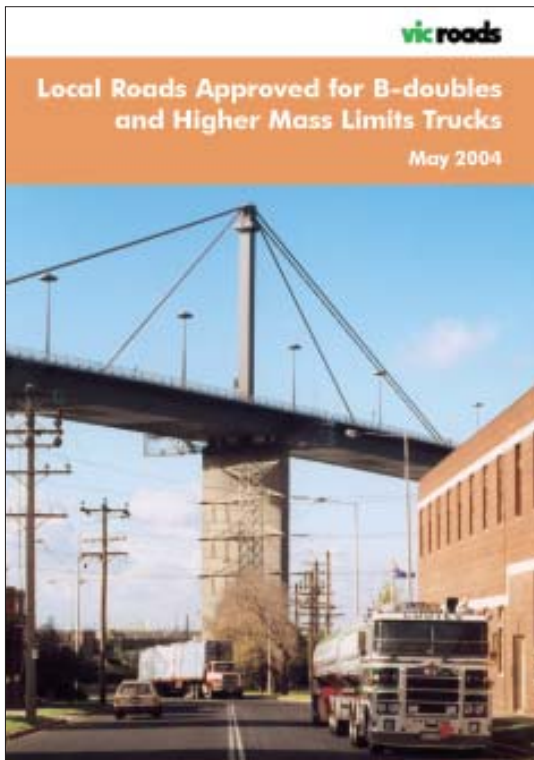

Local Roads Approved for B-doubles and Higher Mass Limits Trucks - May 2004

- 2) The local Council has given an operator a letter supporting the use of a local road and the operator has obtained a VicRoads permit.

See page 2 for the documentation you must carry and produce if required.

Unsuitable Routes



Some routes are unsuitable for long vehicles due to:

- 1) Hilly terrain with relatively narrow, sharp bends; or
- 2) Dense traffic such as in the central business area of Melbourne.



B-doubles, except mini B-doubles up to 50.0 tonnes, must not travel on the roads marked in **orange** on the maps in this information bulletin.

Rigid trucks and semi-trailers operating at general mass limits and Higher Mass Limits may use the roads marked in **orange**.

Limited Capacity Bridges

There are a number of older bridges that have not been designed for today's heavier vehicles. These bridges are marked by the symbols  or  on the attached maps and are named and numbered in Tables 4 and 5.

B-doubles, except Mini B-doubles up to 50.0 tonnes, operating at general mass limits, must not cross the bridges in Table 4 and shown as  in the attached maps.

Higher Mass Limits B-doubles and semi-trailers with tri-axles at Higher Mass Limits must not cross the bridges listed in Tables 4  and 5  or travel on the associated roads marked in **red**. However, they may use part of a **red** road provided a permit is obtained from VicRoads.

Low Clearance Bridges

Drivers need to be familiar with a number of low clearance bridges in Victoria. Low bridges on main roads in rural Victoria are listed by number in Table 3 and are identified on the maps. In addition, the locations of low bridges on main roads in Melbourne are also shown on the attached maps.

Table 3 – Rural Low Clearance Bridge Locations

Low Clearance Bridge Locations	
1. Pyrenees Highway at Maryborough (rail)	Page 23
2. Midland Highway at Castlemaine [Downes Street] (rail)	Page 23
3. Midland Highway at Castlemaine [Rowe Street] (rail)	Page 23
4. Midland Highway at Harcourt (rail)	Page 23
5. Mt Macedon Road at Macedon (rail)	Page 23
6. Heathcote - Kyneton Road at Redesdale (gantry)	Page 23
7. Goulburn Valley Highway, Seymour [Tallarook Street] (rail) - detour via Oak Street, Tarcombe Road, High Street and Wallis Street	Page 23
8. Wangaratta - Yarrawonga Road (Rowan Street) at Wangaratta (rail)	Page 24
9. Marlo Road at Orbost (road under Princes Highway)	Page 25
10. Bairnsdale - Paynesville Road at Bairnsdale (rail and road)	Page 25
11. Stratford - Maffra Road at Stratford (rail)	Page 25
12. Hyland Highway at Traralgon (rail) - detour via Liddiard Street	Page 24
13. Monash Way at Morwell (rail) - detour via Tramway Road	Page 24
14. Mclvor Highway at Bendigo (rail) - detour via Powells Road	Page 23

Note: For details of low bridge locations refer to the current edition of the VicRoads publications, *Height Clearance on Roads* and *Height Under Structures for Permit Vehicles - June 2003*.

Part Loaded B-doubles

To optimise vehicle stability and handling, it is recommended that where a B-double is part loaded, the lead trailer should be loaded in preference to the rear trailer.

Liability

Any unauthorised use of a non-approved road or failure to comply with any of the requirements in this information bulletin will leave the driver and operator liable for prosecution. Breaching of conditions may also incur sanctions leading to possible expulsion from the National Heavy Vehicle Accreditation Scheme.

Safe Travel

The vehicle's registered operator and driver are responsible for planning any journey to ensure that:

- 1) The vehicle only crosses suitable bridges and negotiates curves in a safe manner, bearing in mind that some roads and intersections may not be capable of accommodating vehicles at the allowable dimensions;
- 2) The vehicle is not driven under a bridge or structure if the vehicle's height is the same as or exceeds the height limit on any sign;
- 3) That the clearance to other overhead structures, cables, wires and trees is at least 200 millimetres and sufficient to ensure safe passage; and
- 4) The vehicle is not driven on a road, bridge or structure if it would exceed any posted mass or dimension limit.

Your Responsibility

Every effort has been made to provide accurate information at the time of production of this information bulletin. Any trip hereby permitted is made at the absolute risk of the registered operator and driver of the vehicle.

Application of this Information Bulletin

This information bulletin applies to rigid vehicles, semi-trailer combinations and B-doubles at both general mass limits and Higher Mass Limits.

It does not apply to buses or truck / trailer combinations, including pig, tag or dog trailers.

VicRoads Contact:

For further information, contact VicRoads' Permit Officers on: (03) 9881 8853 or (03) 9302 8405

VicRoads web site: www.vicroads.vic.gov.au

e-mail: cvo@roads.vic.gov.au



Plan your route before starting a trip

B-doubles, except Mini B-doubles up to 50.0 tonnes gross mass, must not cross the bridges listed in Table 4. Map references are either Melways Street Directory (Mel) or VicRoads Country Street Directory (VSD).

Table 4

BRIDGE NO.	ROAD CROSSED	LOCATION	MAP REFERENCE	FEATURE
1	Barwon Heads Rd	Barwon Heads	Mel 233 F10	Barwon River
2	Benambra-Corryong Rd	North of Gibbo River Junction	VSD 51 D5	Exhibition Creek
3	Bright-Tawonga Rd	Germantown		Ovens River
4	Burwood Rd	Hawthorn	Mel 45 A10	Hawthorn-Lilydale Rail line
5	Clunes-Creswick Rd	Clunes	VSD 58 E6	Creswick Creek
6	Dargo Road	Orrs Creek	VSD 65 E9	Orrs Creek
7	Don Rd	North of Launching Place	VSD 80 B5	Myrtle Creek
8	Donnybrook Rd	East of Woodstock	VSD 79 C2	Barbers Creek
9	Dunolly-Eddington Rd	Eddington	VSD 43 F8	Bet Bet Creek
10	Gisborne-Kilmore Rd	Riddells Creek	VSD 60 C9	Melbourne-Murray River
11	Gisborne-Melbourne Rd	Gisborne	Mel 197 F9	Un-named Watercourse
12	Glenferrie Rd	Malvern	VSD 59 B10	Gippsland Rail
13	Grampians Rd	Halls Gap	VSD 56 A4	Fyans Creek - Dellys Br
14	Grange Rd	Burnley	VSD 2H G12	Citylink (Monash Fwy) (MacRobertson Br)
15	Great Ocean Rd	Skenes Creek	VSD 101D5	Browns Creek
16	Great Ocean Rd	Lorne	VSD 101 G3	Cumberland River
17	Great Ocean Rd	Skenes Creek	VSD 101D5	Petticoat Creek
18	High Street	Glen Iris	Mel 59 K9	Gardiners Creek
19	Koo-Wee-Rup-Longwarry Rd	Bayles	VSD 96 B4	No 4 Yallock Drain
20	Koo-Wee-Rup-Longwarry Rd	Bayles	VSD 96 B4	Yallock Outfall Drain
21	Licola Rd	Licola	VSD 82 B4	Macalister River
22	Licola Rd	Cheyne's Bridge	VSD 82 C6	Macalister River
23	McKillops Rd	Cabanandra	VSD 68 C4	Jingallala River
24	McKillops Rd	Wulgulmerang	VSD 67 F2	Little River
25	McKillops Rd	Deddick	VSD 67 H3	Snowy River
26	McKillops Rd	Deddick	VSD 67 J3	Un-named watercourse
27	McKillops Rd	Wulgulmerang	VSD 67 F3	Wulgulmerang Creek
28	Nepean Highway	Dromana	Mel 151 C10	Brokil Creek
29	Omeo Highway	Bingo Munjie Nth	VSD 66 B2	Bingo Munjie Creek
30	Omeo Highway	Anglers Rest	VSD 50 J9	Cobungra River

Table 4 (continued)

BRIDGE NO.	ROAD CROSSED	LOCATION	MAP REFERENCE	FEATURE
31	Orrong Rd cnr Malvern Rd	Toorak	Mel 2M G11	Gippsland Rail
32	Queens Park Rd	Geelong	Mel 451 D4	Barwon River
33	Snowy River Rd	Wulgulmerang	VSD 67 F2	Little River
34	Snowy River Rd	Suggan Buggan	VSD 52 G9	Suggan Buggan River
35	St Kilda St	Elwood	Mel 67 D4	Elwood Canal
36	Tarra Valley Rd	Macks Creek	VSD 98 B9	Tarra River
37	Tarra Valley Rd	Macks Creek	VSD 98 B9	Tarra River
38	Tarra Valley Rd	Macks Creek	VSD 98 B9	Tarra River
39	Tarra Valley Rd	Macks Creek	VSD 98 A9	Tarra River
40	Walhalla Rd	Walhalla	VSD 81 J9	Un-named watercourse
41	Wallen Rd (Swan St)	Hawthorn	Mel 45 A11	Yarra River
42	Warburton-Woods Point Rd	Woods Point	VSD 81 E3	Goulburn River
43	Warburton-Woods Point Rd	Matlock	VSD 81 E3	Morning Star Creek
44	Wattletree Rd	Eltham	Mel 22 A2	Diamond Creek
45	Wattletree Rd	Malvern	Mel 59 B9	Gippsland Rail



Avoid bridges if your vehicle exceeds any posted mass or dimension limit

B-doubles operating at Higher Mass Limits and semi-trailers with a tri-axle group at Higher Mass Limits must not cross the bridges listed in Table 4 and Table 5. Map references are either Melways Street Directory (Mel) or VicRoads Country Street Directory (VSD).

Table 5

BRIDGE NO.	ROAD CROSSED	LOCATION	MAP REFERENCE	FEATURE
46	Briagolong Rd	Stratford	VSD 83 C8	Blackall Creek
47	Dargo Rd	Dargo	VSD 65 F9	Rileys Creek
48	Dohertys Rd	Laverton North	Mel 40 A12	Outfall Sewer
49	Fitzgerald Road	Laverton North	Mel 53 G2	Melb Water Outfall Sewer
50	Geelong-Bacchus Marsh Rd	Bacchus Marsh	Mel 219 G4	Werribee River
51	High Street	Armadale	Mel 558 K7	Gippsland rail
52	Midland Hwy	Benalla	VSD 47 H2	Broken Creek
53	Nepean Hwy	Mordialloc	Mel 92 F1	Mordialloc Creek
54	Normanby Ave	Coburg East	Mel 30 A4	Merri Creek
55	Rushworth-Tatura Rd	Rushworth	VSD 46 B2	Waranga Western Channel
56	Studley Park Road	Kew	Mel 2D F9	Yarra Boulevard
57	Victoria St	Abbottsford	Mel 2H H2	Yarra River



Plan to avoid low bridges

Table 6 - Axle Spacing/Mass Schedule

Distance between outer axles (metres)		Mass Limit (tonnes)	Distance between outer axles (metres)		Mass Limit (tonnes)
Equal to or greater than	Less than		Equal to or greater than	Less than	
3.5	3.7	23.0	10.0	10.2	* 42.5
3.7	3.8	23.5	10.2	10.3	43.0
3.8	4.0	24.0	10.3	10.5	43.5
4.0	4.2	24.5	10.5	10.7	44.0
4.2	4.3	25.0	10.7	10.8	44.5
4.3	4.5	25.5	10.8	11.0	45.0
4.5	4.7	26.0	11.0	11.2	45.5
4.7	4.8	26.5	11.2	11.3	46.0
4.8	5.0	27.0	11.3	11.7	46.5
5.0	5.2	27.5	11.7	12.0	47.0
5.2	5.3	28.0	12.0	12.3	47.5
5.3	5.5	28.5	12.3	12.7	48.0
5.5	5.7	29.0	12.7	13.0	48.5
5.7	5.8	29.5	13.0	13.3	49.0
5.8	6.0	30.0	13.3	13.7	49.5
6.0	6.2	30.5	13.7	14.0	50.0
6.2	6.3	31.0	14.0	14.3	50.5
6.3	6.5	31.5	14.3	14.7	51.0
6.5	6.7	32.0	14.7	15.0	51.5
6.7	6.8	32.5	15.0	15.3	52.0
6.8	7.0	33.0	15.3	15.7	52.5
7.0	7.2	33.5	15.7	16.0	53.0
7.2	7.3	34.0	16.0	16.3	53.5
7.3	7.5	34.5	16.3	16.7	54.0
7.5	7.7	35.0	16.7	17.0	54.5
7.7	7.8	35.5	17.0	17.3	55.0
7.8	8.0	36.0	17.3	17.7	* 55.5
8.0	8.2	36.5	17.7	18.0	56.0
8.2	8.3	37.0	18.0	18.3	56.5
8.3	8.5	37.5	18.3	18.7	57.0
8.5	8.7	38.0	18.7	19.0	57.5
8.7	8.8	38.5	19.0	19.3	58.0
8.8	9.0	39.0	19.3	19.7	58.5
9.0	9.2	39.5	19.7	20.0	59.0
9.2	9.3	40.0	20.0	20.3	59.5
9.3	9.5	40.5	20.3	20.7	60.0
9.5	9.7	41.0	20.7	21.0	60.5
9.7	9.8	41.5	21.0		* 62.5
9.8	10.0	42.0			

* For Higher Mass Limits vehicles see page 7

Table 7 - General Access Axle Spacing/Mass Table for Mini B-doubles

Distance (metres)		Mass Limit (tonnes)	Distance (metres)		Mass Limit (tonnes)
Exceeding	Not Exceeding		Exceeding	Not Exceeding	
3.5	3.7	23.0	8.0	8.2	36.5
3.7	3.8	23.5	8.2	8.3	37.0
3.8	4.0	24.0	8.3	8.5	37.5
4.0	4.2	24.5	8.5	8.7	38.0
4.2	4.3	25.0	8.7	8.8	38.5
4.3	4.5	25.5	8.8	9.0	39.0
4.5	4.7	26.0	9.0	9.2	39.5
4.7	4.8	26.5	9.2	9.3	40.0
4.8	5.0	27.0	9.3	9.5	40.5
5.0	5.2	27.5	9.5	9.7	41.0
5.2	5.3	28.0	9.7	9.8	41.5
5.3	5.5	28.5	9.8	10.0	42.0
5.5	5.7	29.0	10.0	10.5	42.5
5.7	5.8	29.5	10.5	11.0	43.0
5.8	6.0	30.0	11.0	11.5	43.5
6.0	6.2	30.5	11.5	12.0	44.0
6.2	6.3	31.0	12.0	12.5	44.5
6.3	6.5	31.5	12.5	13.0	45.0
6.5	6.7	32.0	13.0	13.5	45.5
6.7	6.8	32.5	13.5	14.0	46.0
6.8	7.0	33.0	14.0	14.5	46.5
7.0	7.2	33.5	14.5	15.0	47.0
7.2	7.3	34.0	15.0	15.5	47.5
7.3	7.5	34.5	15.5	16.0	48.0
7.5	7.7	35.0	16.0	16.5	48.5
7.7	7.8	35.5	16.5	17.0	49.0
7.8	8.0	36.0	17.0	17.5	49.5
			17.5		50.0

Index of Maps

Map	Page
Interstate Routes	19
North Western Victoria	20 - 21
South Western Victoria	22 - 23
Central Victoria	24
Eastern Victoria	25
North Western Melbourne	26
South Eastern Melbourne	27
Inner Melbourne	28 - 29
Mornington Peninsula	30 - 31
Ballarat	32
Benalla	33
Bendigo	34
Geelong	35
Hamilton	36
Kerang	36
Mansfield	37
Maryborough	37
Seymour	38
Shepparton	38
Warrnambool	39
Wodonga	39



Tipping B-double

VicRoads Contacts

Area	Telephone No.	Fax No.
Melbourne North & West	03 9302 8405	03 9302 8407
Melbourne East & South	03 9881 8853	03 9881 8854
Gippsland	03 5135 3037	03 5135 3025
Northern Victoria	03 5434 5000	03 5434 5003
North East Victoria	03 5761 1829	03 5762 4980
Western Victoria	03 5333 8779	03 5333 8771
South West Victoria	03 5225 2504	03 5221 6102